

NHD-24064WG-ATMI-VZ#

Graphic Liquid Crystal Display Module

NHD-	Newhaven Display
24064-	240 x 64 Pixels
WG-	Display Type: Graphic
A-	Model
T-	Side White LED Backlight
M-	STN- Blue (-)
I-	Transmissive, 6:00 Optimal View, Wide Temperature
VZ#-	With Built-in Negative Voltage Supply
	RoHS Compliant

Newhaven Display International, Inc.

2661 Galvin Ct.

Elgin IL, 60124

Ph: 847-844-8795

Fax: 847-844-8796

www.newhavendisplay.com

nhtech@newhavendisplay.com

nhsales@newhavendisplay.com

Document Revision History

Revision	Date	Description	Changed by
0	2/28/2008	Initial Release	-
1	4/9/2010	User guide reformat	BE
2	5/13/2010	Updated Backlight Supply Voltage and Current	MC
3	11/16/2010	Pin description update	AK
4	4/11/2011	Mechanical drawing updated	AK
5	5/16/2012	Optical characteristics updated	AK
6	5/3/2013	Updated electrical and optical characteristics. Updated wiring diagram and drawing page. Added font table.	JN
7	11/23/16	Mechanical Drawing and Electrical Characteristics Updated	SB

Functions and Features

- 240 x 64 pixels
- Built-in RA6963 controller
- +5.0V Power Supply
- 1/64 duty
- RoHS Compliant

Mechanical Drawing

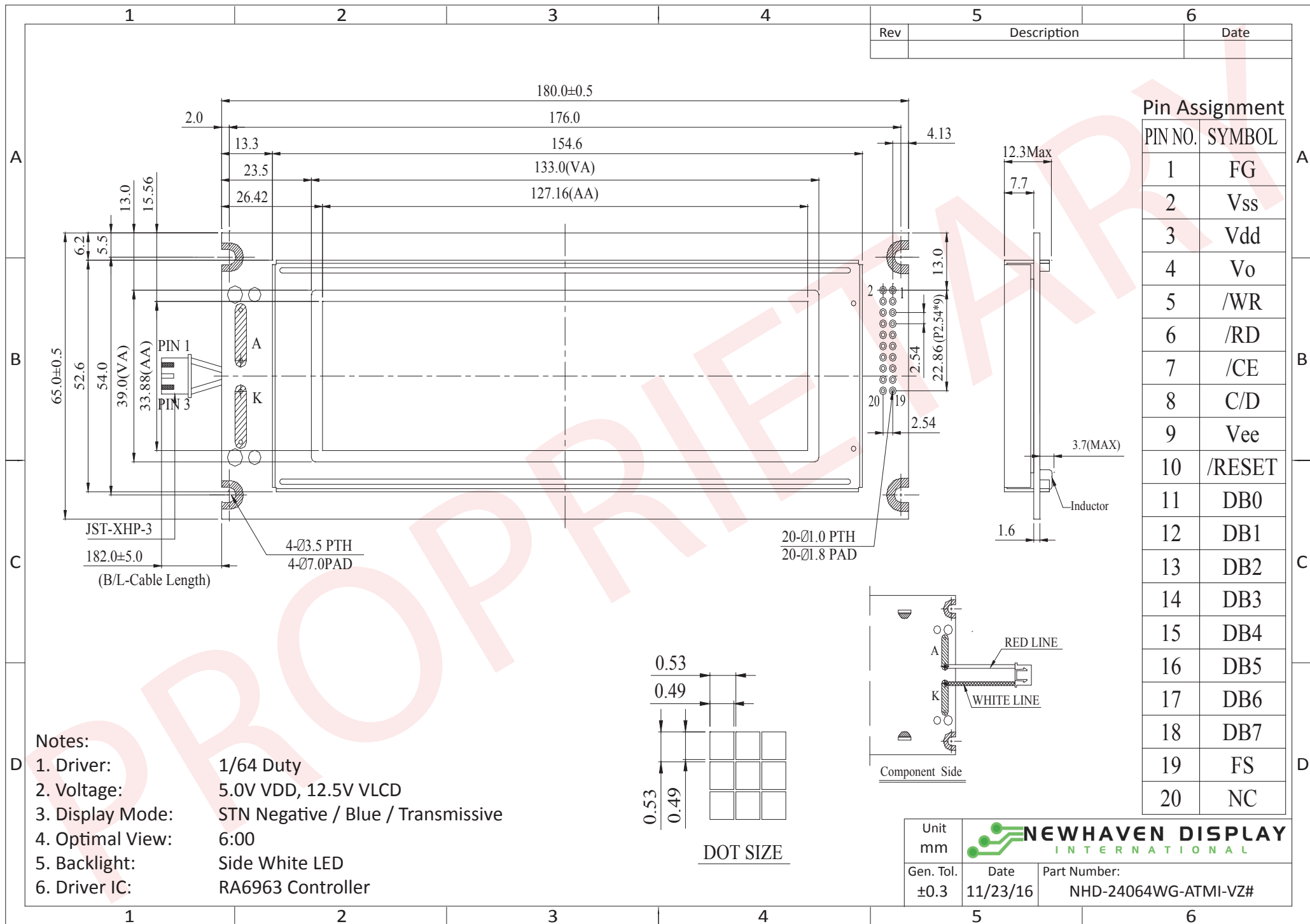

The information contained herein is the exclusive property of Newhaven Display International, Inc. and shall not be copied, reproduced, and/or disclosed in any format without permission.

Pin Description and Wiring Diagram

Pin No.	Symbol	External Connection	Function Description
1	FGND	Power Supply	Frame Ground
2	V _{SS}	Power Supply	Ground
3	V _{DD}	Power Supply	Supply Voltage for logic (+5.0V)
4	V ₀	Adj. Power Supply	Supply Voltage for Contrast (approx. -7.5V)
5	/WR	MPU	Active LOW Write signal
6	/RD	MPU	Active LOW Read signal
7	/CE	MPU	Active LOW Chip Enable
8	C/D	MPU	Register Select signal C/D=0: DATA C/D=1: COMMAND
9	V _{EE}	Power Supply	Negative voltage output (-10V)
10	RES	MPU	Active LOW reset signal
11~18	DB0~DB7	MPU	Bi-directional 8-bit data bus
19	FS	MPU	Font Select: 1=6x8 fonts, 0=8x8 fonts
20	NC	-	No Connect
A	LED+	Power Supply	Backlight Anode (+3.5V)
K	LED-	Power Supply	Backlight Cathode (Ground)

Recommended LCD connector: 2.54mm pitch pins

Backlight connector: JST-XHP-3 **Mates with:** B 3B-XH-A

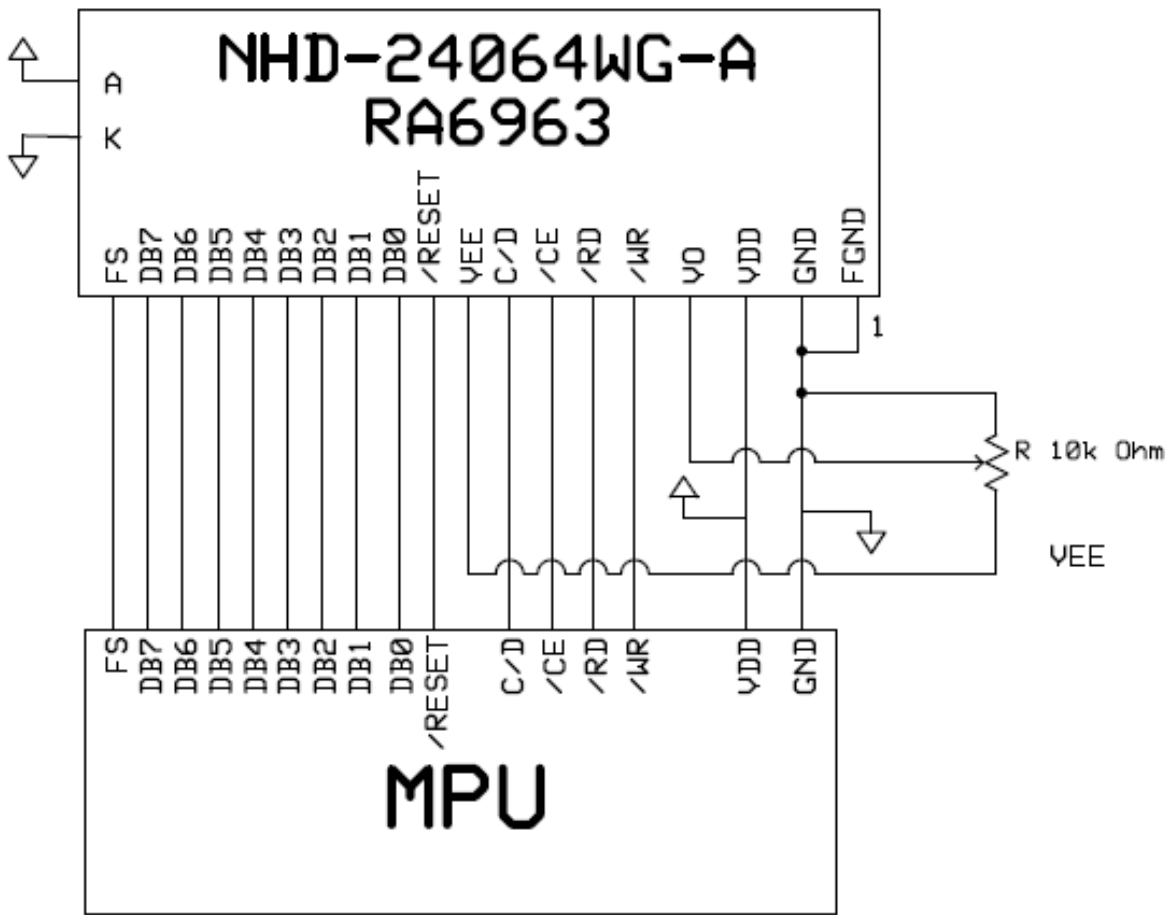

Electrical Characteristics

Item	Symbol	Condition	Min.	Typ.	Max.	Unit
Operating Temperature Range	T_{OP}	Absolute Max	-20	-	+70	°C
Storage Temperature Range	T_{ST}	Absolute Max	-30	-	+80	°C
Supply Voltage	V_{DD}	-	3.0	5.0	5.5	V
Supply Current	I_{DD}	$V_{DD} = 5.0V$ $T_{OP} = 25^{\circ}C$	12	16	20	mA
Supply for LCD (contrast)	V_{LCD}		12.1	12.5	12.9	V
"H" Level input	V_{IH}	-	$V_{DD} - 2.2$	-	V_{DD}	V
"L" Level input	V_{IL}	-	V_{SS}	-	0.8	V
"H" Level output	V_{OH}	-	$V_{DD} - 0.3$	-	V_{DD}	V
"L" Level output	V_{OL}	-	V_{SS}	-	0.3	V
Backlight Supply Voltage	V_{LED}	-	3.4	3.5	3.6	V
Backlight Supply Current	I_{LED}	$V_{LED} = 3.5V$	40	80	100	mA
Backlight Lifetime	-	$I_{LED} = 80mA$	-	50,000	-	Hrs.

Optical Characteristics

Item	Symbol	Condition	Min.	Typ.	Max.	Unit
Optimal Viewing Angles	Top	$CR \geq 2$	-	20	-	°
	Bottom		-	40	-	°
	Left		-	30	-	°
	Right		-	30	-	°
Contrast Ratio	CR	-	2	3	-	-
Response Time	Rise	$T_{OP} = 25^{\circ}C$	-	200	300	ms
	Fall		-	250	350	ms

Controller Information

Built-in RA6963 controller.

Please download specification at http://www.newhavendisplay.com/app_notes/RA6963.pdf

Table of Commands

Command	Code	D1	D2	Function
Registers Setting	00100001	X address	Y address	Set cursor pointer
	00100010	Data	00h	Set Offset Register
	00100100	Low address	High address	Set Address pointer
Set Control Word	01000000	Low address	High address	Set Text Home Address
	01000001	Columns	00h	Set Text Area
	01000010	Low address	High address	Set Graphic Home Address
	01000011	Columns	00h	Set Graphic Area
Mode Set	1000X000	--	--	OR mode
	1000X001	--	--	EXOR mode
	1000X011	--	--	AND mode
	1000X100	--	--	Text Attribute mode
	10000XXX	--	--	Internal CG ROM mode
	10001XXX	--	--	External CG RAM mode
Display Mode	10010000	--	--	Display off
	1001XX10	--	--	Cursor on, blink off
	1001XX11	--	--	Cursor on, blink on
	100101XX	--	--	Text on, graphic off
	100110XX	--	--	Text off, graphic on
	100111XX	--	--	Text on, graphic on
Cursor Pattern Select	10100000	--	--	1-line cursor
	10100001	--	--	2-line cursor
	10100010	--	--	3-line cursor
	10100011	--	--	4-line cursor
	10100100	--	--	5-line cursor
	10100101	--	--	6-line cursor
	10100110	--	--	7-line cursor
	10100111	--	--	8-line cursor
Data Read/Write	11000000	Data	--	Data Write and Increment ADP
	11000001	--	--	Data Read and Increment ADP
	11000010	Data	--	Data Write and Decrement ADP
	11000011	--	--	Data Read and Decrement ADP
	11000100	Data	--	Data Write and Non-variable ADP
	11000101	--	--	Data Read and Non-variable ADP
Data auto Read/Write	10110000	--	--	Set Data Auto Write
	10110001	--	--	Set Data Auto Read
	10110010	--	--	Auto Reset
Screen Peek	11100000	--	--	Screen Peek
Screen Copy	11101000			Screen Copy
Bit Set/Reset	11110XXX	--	--	Bit Reset
	11111XXX	--	--	Bit Set
	1111X000	--	--	Bit 0 (LSB)
	1111X001	--	--	Bit 1
	1111X010	--	--	Bit 2
	1111X011	--	--	Bit 3
	1111X100	--	--	Bit 4
	1111X101	--	--	Bit 5
	1111X110	--	--	Bit 6
	1111X111	--	--	Bit 7 (MSB)
Screen Reverse	11010000	Data	--	Whole screen reverse

Timing Characteristics

($V_{DD}=+5V\pm 5\%$, $GND=0V$, $T_a = -20$ to $+70^{\circ}C$)

Item	Symbol	Test Conditions	Min.	Max.	Unit
C/ \overline{D} Set Up Time	t_{CDS}	--	100	--	ns
C/ \overline{D} Hold Time	t_{CDH}	--	10	--	ns
\overline{CE} , \overline{RD} , \overline{WR} Pulse Width	t_{CE} , t_{RD} , t_{WR}	--	80	--	ns
Data Set Up Time	t_{DS}	--	80	--	ns
Data Hold Time	t_{DH}	--	40	--	ns
Access Time	t_{ACC}	--	--	150	ns
Output Hold Time	t_{OH}	--	10	50	ns

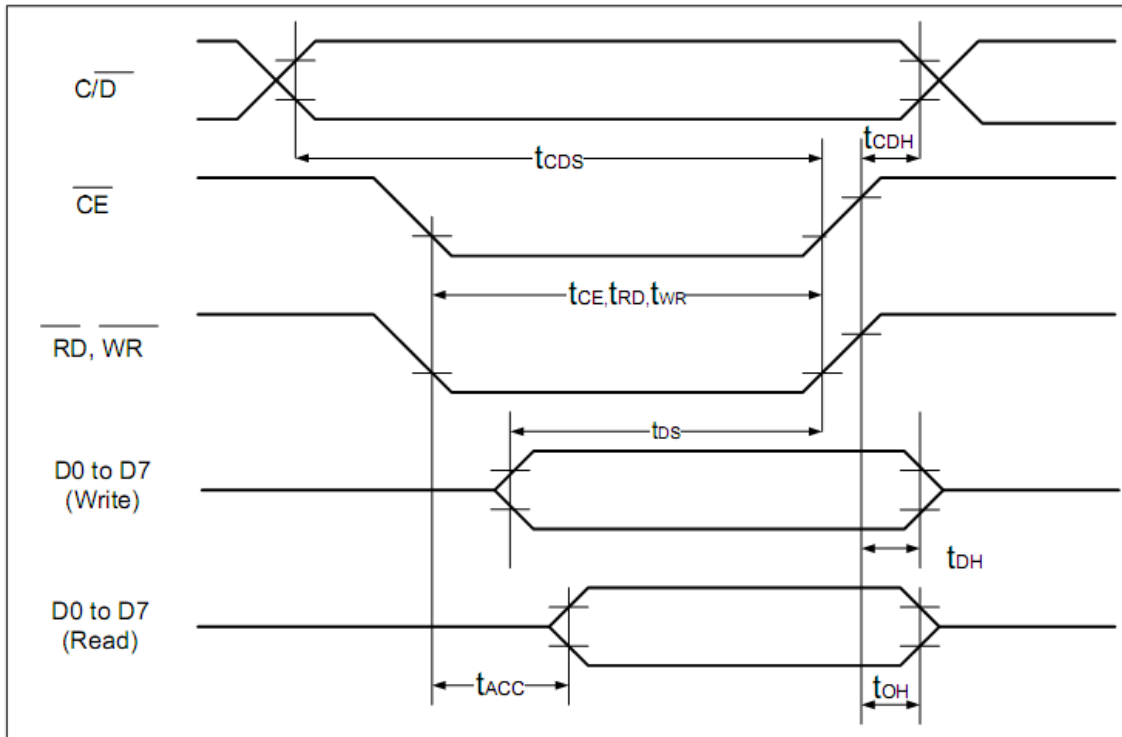

Built-in Font Table

LSB MSB	0	1	2	3	4	5	6	7	8	9	A	B	C	D	E	F
0		!	"	#	\$	%	&	'	()	*	+	,	-	.	/
1	0	1	2	3	4	5	6	7	8	9	:	;	<	=	>	?
2	a	A	B	C	D	E	F	G	H	I	J	K	L	M	N	O
3	P	Q	R	S	T	U	U	W	X	Y	Z	[\]	^	_
4	Y	a	b	c	d	e	f	g	h	i	j	k	l	m	n	o
5	P	q	r	s	t	u	v	w	x	y	z	{		}	~	
6	Q	U	E	A	A	A	A	Q	E	E	E	i	i	i	A	A
7	E	æ	Æ	ö	ö	ö	ü	ü	ü	ö	ö	ø	ø	¥	℞	ℱ

Example Initialization Program

```
void command(int A)
{
    P1 = A;
    ID = 1;           //Command
    CE = 0;
    WRT = 0;
    WRT = 1;
    CE = 1;
}

void data(int A)
{
    P1 = A;
    ID = 0;          //Data
    CE = 0;
    WRT = 0;
    WRT = 1;
    CE = 1;
}

void init()
{
    RST = 1;
    RDD = 1;
    F_S = 1;
    data(0x00);
    data(0x00);
    commnd(0x40);    //Set Text Home Address
    data(0x00);      //Low Address Columns
    data(0x40);      //High Address
    command(0x42);   //Set Graphic Home Address
    data(0x1E);      //Low Address Columns
    data(0x00);      //High Address
    command(0x41);   //Set Text Area
    data(0x1E);      //Low Address Columns
    data(0x00);      //High Address
    command(0x43);   //Set Graphic Areaa
    command(0x80);   //Mode Set to 'OR' mode
}
```

Quality Information

Test Item	Content of Test	Test Condition	Note
High Temperature storage	Endurance test applying the high storage temperature for a long time.	+80°C , 200hrs	2
Low Temperature storage	Endurance test applying the low storage temperature for a long time.	-30°C , 200hrs	1,2
High Temperature Operation	Endurance test applying the electric stress (voltage & current) and the high thermal stress for a long time.	+70°C 200hrs	2
Low Temperature Operation	Endurance test applying the electric stress (voltage & current) and the low thermal stress for a long time.	-20°C , 200hrs	1,2
High Temperature / Humidity Operation	Endurance test applying the electric stress (voltage & current) and the high thermal with high humidity stress for a long time.	+60°C , 90% RH , 96hrs	1,2
Thermal Shock resistance	Endurance test applying the electric stress (voltage & current) during a cycle of low and high thermal stress.	-20°C,30min -> 25°C,5min -> 70°C,30min = 1 cycle 10 cycles	
Vibration test	Endurance test applying vibration to simulate transportation and use.	10-55Hz , 15mm amplitude. 60 sec in each of 3 directions X,Y,Z For 15 minutes	3
Static electricity test	Endurance test applying electric static discharge.	VS=800V, RS=1.5kΩ, CS=100pF One time	

Note 1: No condensation to be observed.

Note 2: Conducted after 4 hours of storage at 25°C, 0%RH.

Note 3: Test performed on product itself, not inside a container.

Precautions for using LCDs/LCMs

See Precautions at www.newhavendisplay.com/specs/precautions.pdf

Warranty Information and Terms & Conditions

http://www.newhavendisplay.com/index.php?main_page=terms